

Directional spool valves, directly operated, with manual and fluid logics actuation

Type WMM, WN and WP

RE 22334

Edition: 2013-04

Replaces: 22331



- ▶ Size 10
- ▶ Component series 5X
- ▶ Maximum operating pressure 350 bar [5076 psi]
- ▶ Maximum flow 160 l/min [42.3 US gpm]

Features

- ▶ 4/3-, 4/2- or 3/2-way version
- ▶ Porting pattern according to ISO 4401-05-04-0-05 and NFPA T3.5.1 R2-2002 D05
- ▶ Types of actuation:
 - Hand lever
 - Pneumatic
 - Hydraulic

Contents

| | |
|-----------------------|-----------|
| Features | 1 |
| Ordering code | 2 |
| Symbols | 3 |
| Types of actuation | 4, 5 |
| Function, section | 6 |
| Technical data | 7 |
| Characteristic curves | 8 |
| Performance limits | 9, 10 |
| Dimensions | 11 ... 14 |
| More information | 14 |

Ordering code

| | | | | | | | | | | |
|----|----|-----------|----|-----------|----|----|----|----|----|----|
| 01 | 02 | 03 | 04 | 05 | 06 | 07 | 08 | 09 | 10 | 11 |
| | | 10 | | 5X | / | | / | | | * |

| | | |
|----|--------------|----------|
| 01 | 3 main ports | 3 |
| | 4 main ports | 4 |

Types of actuation

| | | |
|----|---|------------|
| 02 | - Manual | |
| | Hand lever | WMM |
| | - Fluidic | |
| | Pilot pressure 1.5 ... 10 bar [22 ... 145 psi] | WN |
| | Pilot pressure 8 ... 160 bar [116 ... 2321 psi] | WP |

| | | |
|----|---------|-----------|
| 03 | Size 10 | 10 |
|----|---------|-----------|

| | | |
|----|--|--|
| 04 | Symbols e.g. C, E, EA, EB, etc; possible versions see page 3 ... 5 | |
|----|--|--|

| | | |
|----|--|-----------|
| 05 | Component series 50 ... 59 (50 ... 59: Unchanged installation and connection dimensions) | 5X |
|----|--|-----------|

| | | |
|----|--|----------------|
| 06 | With spring return | no code |
| | Without spring return (not for valves with 3 switching positions and version "WMM") | O |
| | With detent (not for versions "WN" and "WP") | F |
| | Without spring return with detent (not for valves with 3 switching positions and version "WMM") | OF |

Corrosion protection

| | | |
|----|--|----------------|
| 07 | Standard corrosion protection | no code |
| | Improved corrosion protection (720 h salt spray test according to EN ISO 9227; only version "WMM") | J4 |

Throttle insert ¹⁾

| | | | | |
|---|--------------------------------|-------------------------|--------------|--------------|
| 08 | Without throttle insert | no code | | |
| | With throttle insert: | | | |
| | Connection | Throttle Ø in mm [inch] | | |
| | | 0.8 [0.031] | 1.0 [0.039] | 1.2 [0.047] |
| | P | = B08 | = B10 | = B12 |
| | A | = H08 | = H10 | = H12 |
| | B | = R08 | = R10 | = R12 |
| | A and B | = N08 | = N10 | = N12 |
| T ²⁾ | = X08 | = X10 | = X12 | |
| Further throttle insert diameters upon request. | | | | |

Seal material

| | | |
|----|--|-----------|
| 09 | NBR seals | M |
| | FKM seals | V |
| | Seals for HFC hydraulic fluids | MH |
| | Attention: Observe compatibility of seals with hydraulic fluid used! | |

Pilot oil port

| | | |
|----|---|------------|
| 10 | Whitworth pipe thread G1/4 | - |
| | UNF thread 7/16" - 20 UNF (only versions "WN" and "WP") | /12 |
| 11 | Further details in the plain text | |

¹⁾ If the admissible valve performance limits are exceeded, throttle inserts must be installed (performance limits see page 9).

²⁾ If throttle inserts are used in channel T, the pressure in the working ports and for connection to the tank chambers must not exceed 210 bar.

Symbols

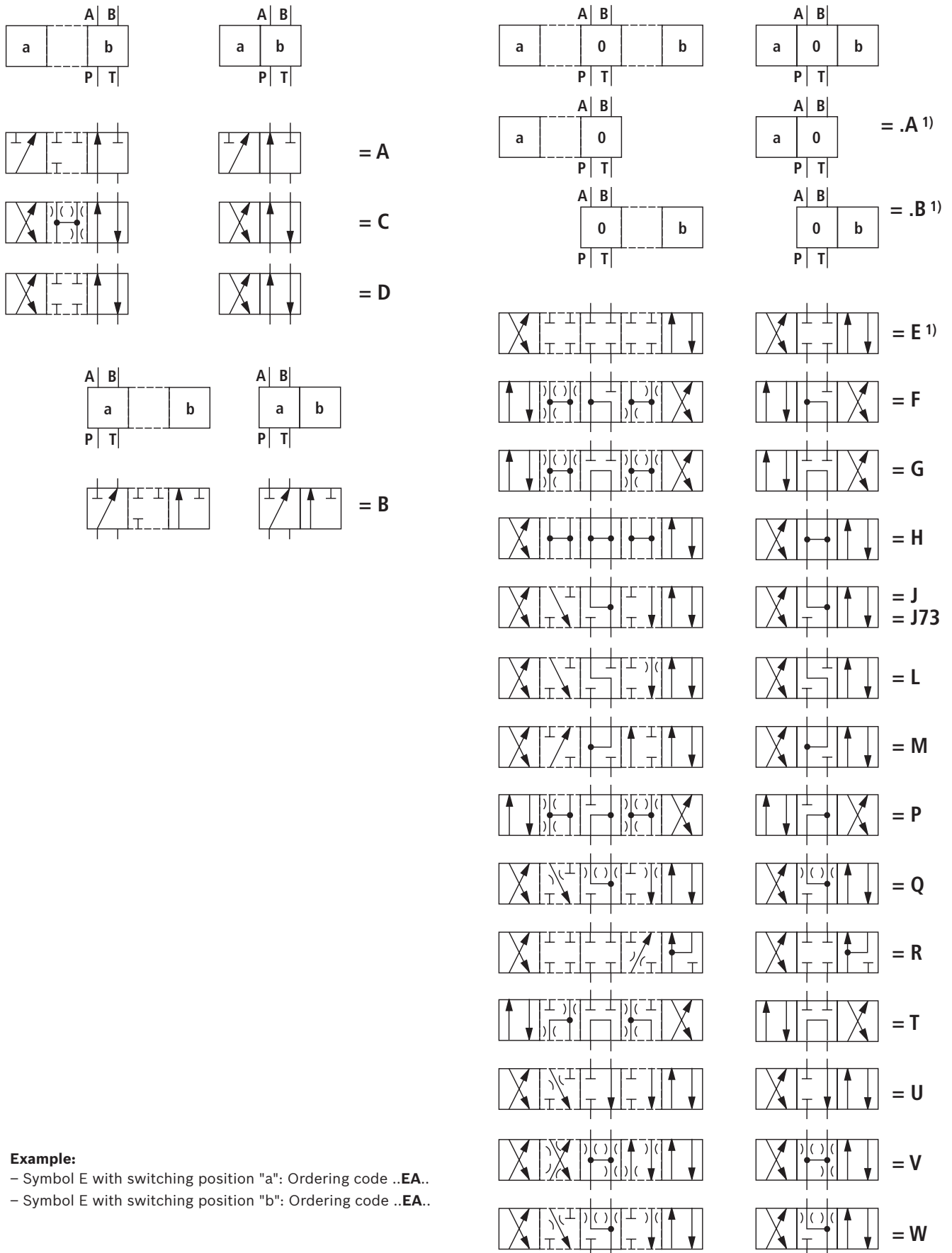

1) **Example:**
 - Symbol E with switching position "a": Ordering code ..EA..
 - Symbol E with switching position "b": Ordering code ..EA..

Types of actuation: Type WMM

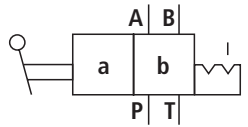
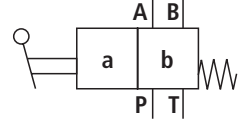
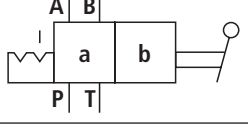
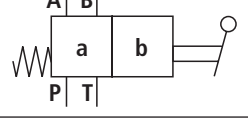
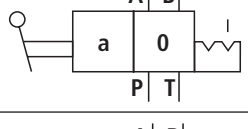
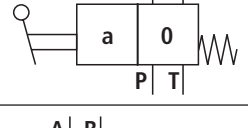
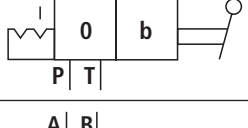
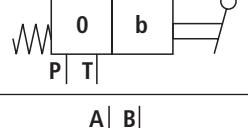
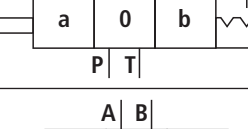
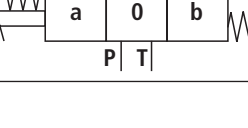
| Symbol | Ordering code | | Type of actuation | |
|--|----------------|--------|--|----|
| | Actuating side | Detent | Hand lever | |
| A, C, D | | ../F.. |  | 2) |
| | | |  | 2) |
| B | | ../F.. |  | 3) |
| | | |  | 3) |
| E, F, G, H, J, J73, L, M, P, Q, R, T, U, V, W | "a" 1) = .A | ../F.. |  | 2) |
| | | |  | 2) |
| | "b" 1) = .B | ../F.. |  | 3) |
| | | |  | 3) |
| | | ../F.. |  | 4) |
| | | |  | 4) |

1) See symbols on page 3

2) See pos. 2, page 11

2) See pos. 1, page 11

2) See pos. 3, page 11

Types of actuation: WN and WP

| Symbol | Ordering code Actuating side | Detent | Type of actuation Fluidic |
|---------------------|---------------------------------|---------|------------------------------|
| A, C, D | | | |
| | | ../O.. | |
| | | ../OF.. | |
| B | | | |
| E, G, H, J, L, U | "a" ¹⁾ = .A | | |
| | "b" ¹⁾ = .B | | |
| | | | |

¹⁾ See symbols on page 3

Function, section

Valves of type WMM are manually actuated directional spool valves, valves of type WN and WP are fluidically actuated directional spool valves. They control the start, stop and direction of a flow.

The directional valves basically consist of housing (1), one type of actuation (2.1) (hand lever) or two types of actuation (2.2) (hydraulic, pneumatic

actuation cylinder), control spool (3), and one or two return springs (4).

When de-energized, the control spool (3) is held in the central position or in the initial position by the return springs (4) (except for version "O").

The control spool (3) is moved to the desired spool position by means of the types of actuation.

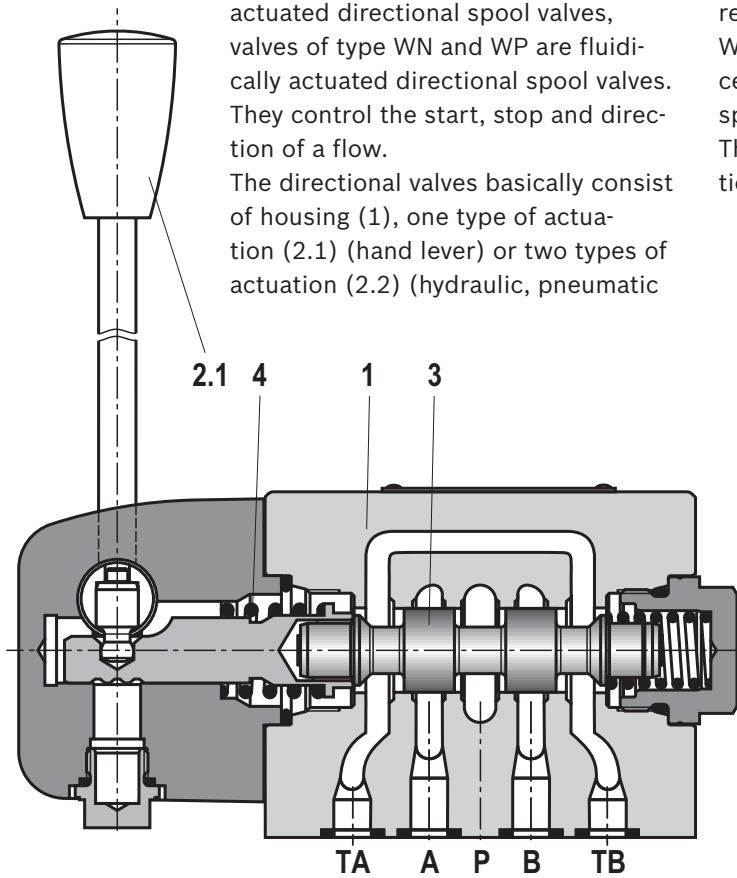

Type 4WMM 10 E5X/...

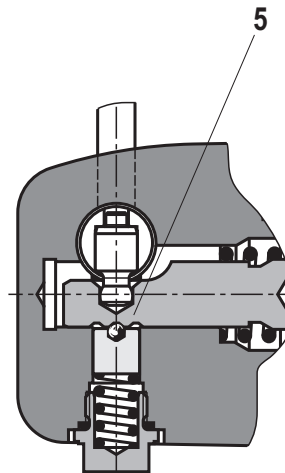

Type 4WMM 10 D5X/F/...
(with detent)

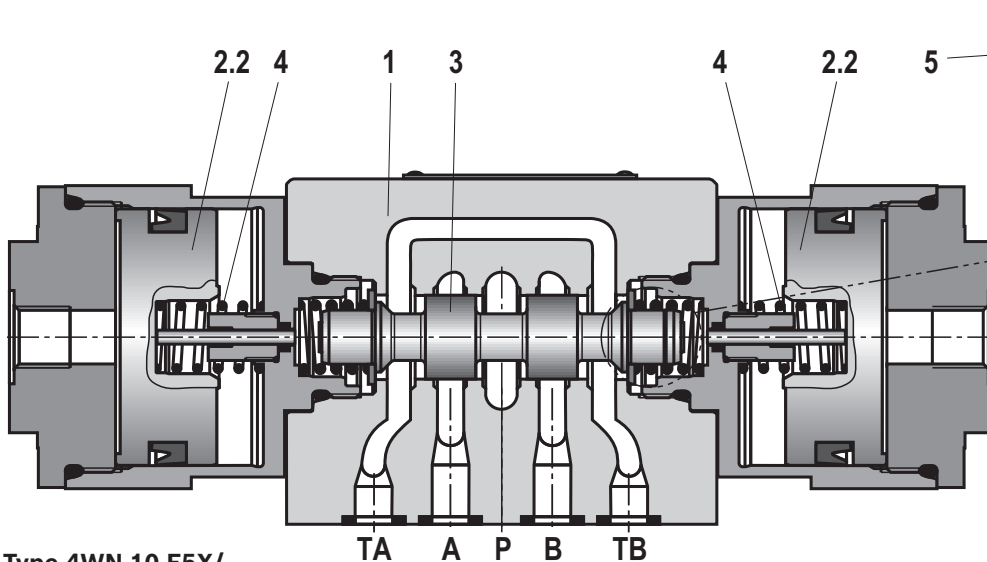

Type 4WN 10 E5X/...

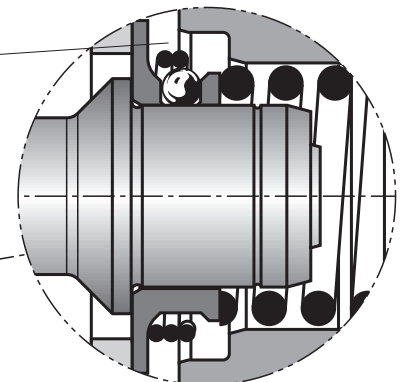

Type 4WN 10 D5X/OF...

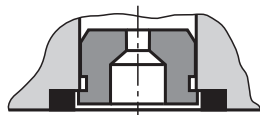

Throttle insert

The use of a throttle insert is required when, due to prevailing operating conditions, flows occur during the switching processes which exceed the performance limit of the valve.

Technical data

(for applications outside these parameters, please consult us!)

| general | | | |
|---------------------------|------------------------|----------|---|
| Type | | | WN WP WMM |
| Weight | - 1 actuation cylinder | kg [lbs] | 3.4 [7.5] |
| | - 2 actuation cylinder | kg [lbs] | 4.8 [10.6] |
| Actuating force | - With detent "F" | N [lbf] | - |
| | - With spring return | N [lbf] | - |
| Installation position | | Any | |
| Ambient temperature range | | °C [°F] | -20 ... +70 [-4 ... +158] (NBR seals) -15 ... +70 [-59 ... +158] (FKM seals) |
| Storage temperature range | | °C [°F] | -20 ... +50 [-4 ... +122] |

| hydraulic | | | |
|--|-----------------|--------------------------------------|---|
| Maximum operating pressure | - Ports A, B, P | bar [psi] | 350 [5076] |
| | - Port T | bar [psi] | 210 [3050] Tank pressure (standard) With symbols A or B, port T must be used as a leakage port if the operating pressure exceeds the admissible tank pressure. |
| Pilot pressure ¹⁾ | | bar [psi] | 1.5 ... 10 [22 ... 145 psi] 8 ... 160 [116 ... 2321 psi] - |
| Maximum flow | | l/min [US gpm] | 160 [42.3] |
| Pilot volume | | cm ³ [inch ³] | 23.7 [1.45] 6.9 [0.42] - |
| Hydraulic fluid | | | See table below |
| Hydraulic fluid temperature range (at the valve working ports) | | °C [°F] | -20 ... +80 [-4 ... +176] (NBR seals) -15 ... +80 [-59 ... +176] (FKM seals) |
| | | mm ² /s [SUS] | 2.8 ... 500 [35 ... 2320] |
| Maximum permitted degree of contamination of the hydraulic fluid - cleanliness class according to ISO 4406 (c) | | | Class 20/18/15 ²⁾ |

| Hydraulic fluid | Classification | Suitable sealing materials | Standards |
|---------------------------------------|----------------------------|---|------------|
| Mineral oils and related hydrocarbons | HL, HLP, HLPD, HVLP, HVLDP | NBR, FKM | DIN 51524 |
| Bio-degradable | - insoluble in water | HETG | VDMA 24568 |
| | | HEES | |
| | - soluble in water | HEPG | VDMA 24568 |
| Flame-resistant | - water-free | HFDU, HFDR | ISO 12922 |
| | - containing water | HFC (Fuchs Hydrotherm 46M, Petrofer Ultra Safe 620) | ISO 12922 |

**Important information on hydraulic fluids**

- For more information and data on the use of other hydraulic fluids, refer to data sheet 90220 or contact us.
- There may be limitations regarding the technical valve data (temperature, pressure range, life cycle, maintenance intervals, etc).

► Flame-resistant – contains water:

- Maximum pressure differential per control edge 50 bar
- Pressure pre-loading at the tank port > 20% of the pressure differential, otherwise increased cavitation
- Life cycle as compared to operation with mineral oil HL, HLP 50 to 100%

¹⁾ The information given only applies if the actuation pressure is applied directly to the valve.

²⁾ The cleanliness classes specified for the components must be adhered to in hydraulic systems. Effective filtration prevents faults and at the same time increases the life cycle of the components. To select filters, see www.boschrexroth.com/filter.

Characteristic curves

(measured with HLP46, $\vartheta_{oil} = 40 \pm 5 \text{ }^\circ\text{C}$ [$104 \pm 9 \text{ }^\circ\text{F}$])

Δp - q_v characteristic curve

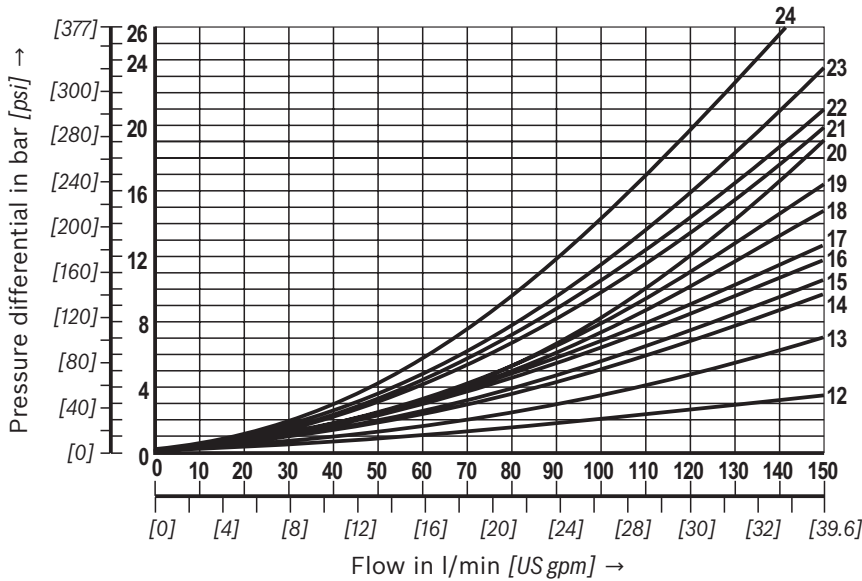
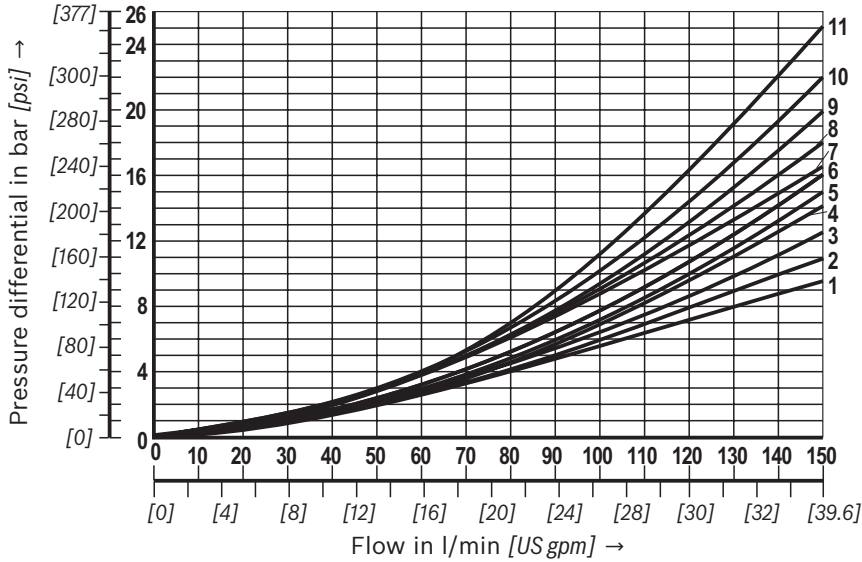

| Symbol | Direction of flow | | | |
|--------|-------------------|-------|-------|-------|
| | P - A | P - B | A - T | B - T |
| A; B | 6 | 6 | - | - |
| C | 1 | 2 | 5 | 7 |
| D | 2 | 2 | 5 | 7 |
| E | 17 | 16 | 19 | 21 |
| F | 2 | 3 | 22 | 23 |
| G | 4 | 4 | 24 | 24 |
| H | 14 | 14 | 20 | 21 |
| J | 3 | 3 | 9 | 11 |
| J73 | 22 | 21 | 23 | 24 |
| L | 3 | 3 | 9 | 9 |
| M | 14 | 14 | 6 | 8 |
| P | 17 | 14 | 20 | 23 |
| Q | 16 | 17 | 4 | 8 |
| R | 18 | 21 | 18 | 24 |
| T | 18 | 4 | 10 | 24 |
| U | 3 | 3 | 6 | 11 |
| V | 17 | 17 | 18 | 20 |
| W | Upon request | | | |

Central position:

| Symbol | Direction of flow | | | | |
|--------|-------------------|-------|-------|-------|-------|
| | P - A | P - B | B - T | A - T | P - T |
| H | 12 | 12 | 13 | 13 | 15 |

Performance limits

(measured with HLP46, $\vartheta_{oil} = 40 \pm 5 \text{ }^\circ\text{C}$ [$104 \pm 9 \text{ }^\circ\text{F}$])

Notice!

The specified performance limits are valid for operation with two directions of flow (e. g. from P to A and simultaneous return flow from B to T).

Due to the flow forces acting within the valves, the

admissible switching power limit may be considerably lower with only one direction of flow (e. g. from P to A while port B is blocked).

In such cases, please consult us.

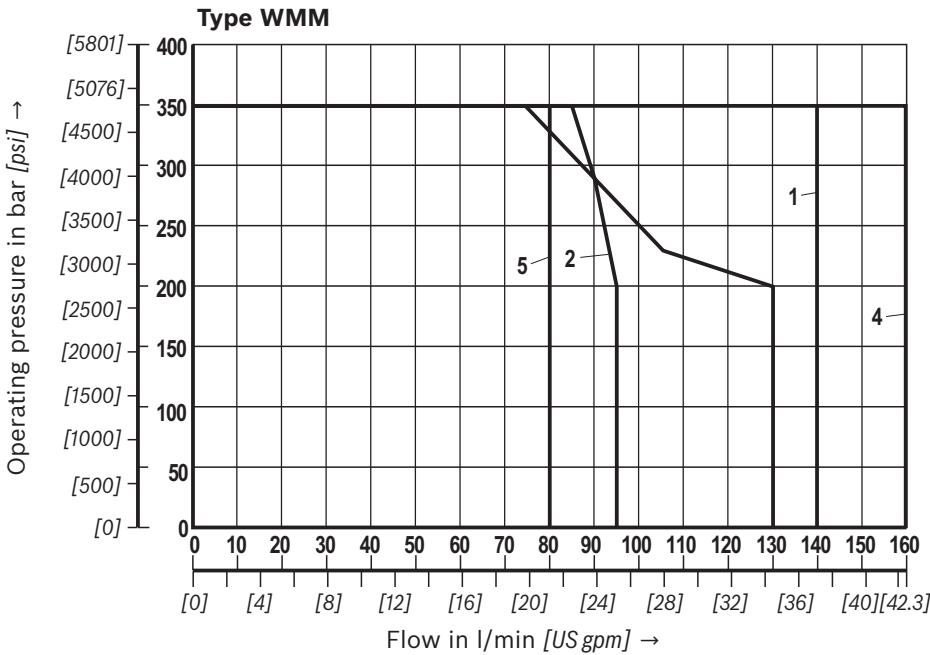

With spring return "-"

| Characteristic curve | Symbol |
|----------------------|-----------------------------------|
| 1 | C, D, E, J, J73, L, M, Q, U, V, W |
| 2 | H |
| 3 | T, G |

With detent "F"

| Characteristic curve | Symbol |
|----------------------|-----------------------------|
| 4 | C, D, E, J, J73, L, M, Q, U |
| 5 | T, G, H |

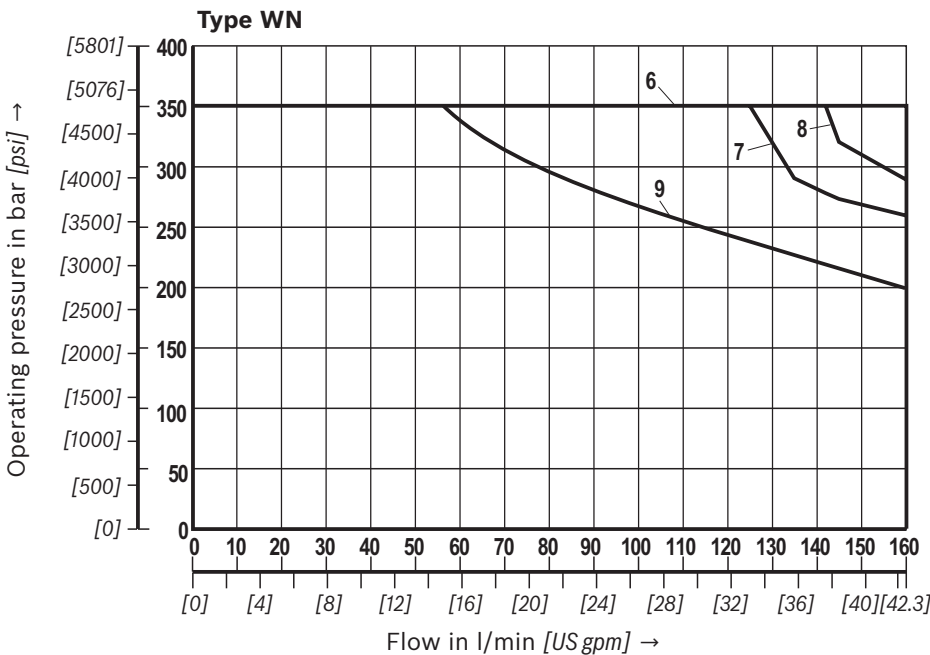

| Characteristic curve | Symbol |
|----------------------|---------------------------------|
| 6 | C, C/OF, D, D/OF, E, J, L, M, U |
| 7 | H |
| 8 | G |
| 9 | A, B |

Performance limits

(measured with HLP46, $\vartheta_{oil} = 40 \pm 5 \text{ }^\circ\text{C}$ [$104 \pm 9 \text{ }^\circ\text{F}$])

Notice!

The specified performance limits are valid for operation with two directions of flow (e. g. from P to A and simultaneous return flow from B to T).

Due to the flow forces acting within the valves, the admissible switching power limit may be considerably

lower with only one direction of flow (e. g. from P to A while port B is blocked).
In such cases, please consult us.

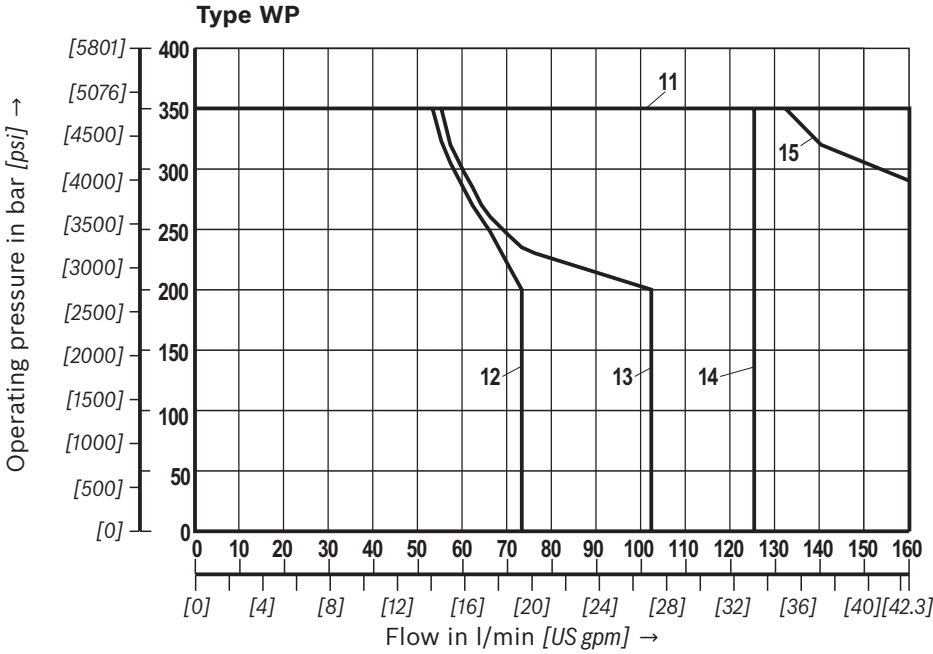

| Characteristic curve | Symbol |
|----------------------|---------------------------------|
| 11 | C, C/OF, D, D/OF, E, J, L, M, U |
| 12 | B |
| 13 | A |
| 14 | G |
| 15 | H |

Dimensions: Type WMM
(dimensions in mm [inch])

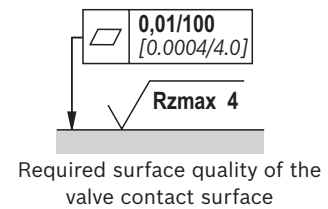
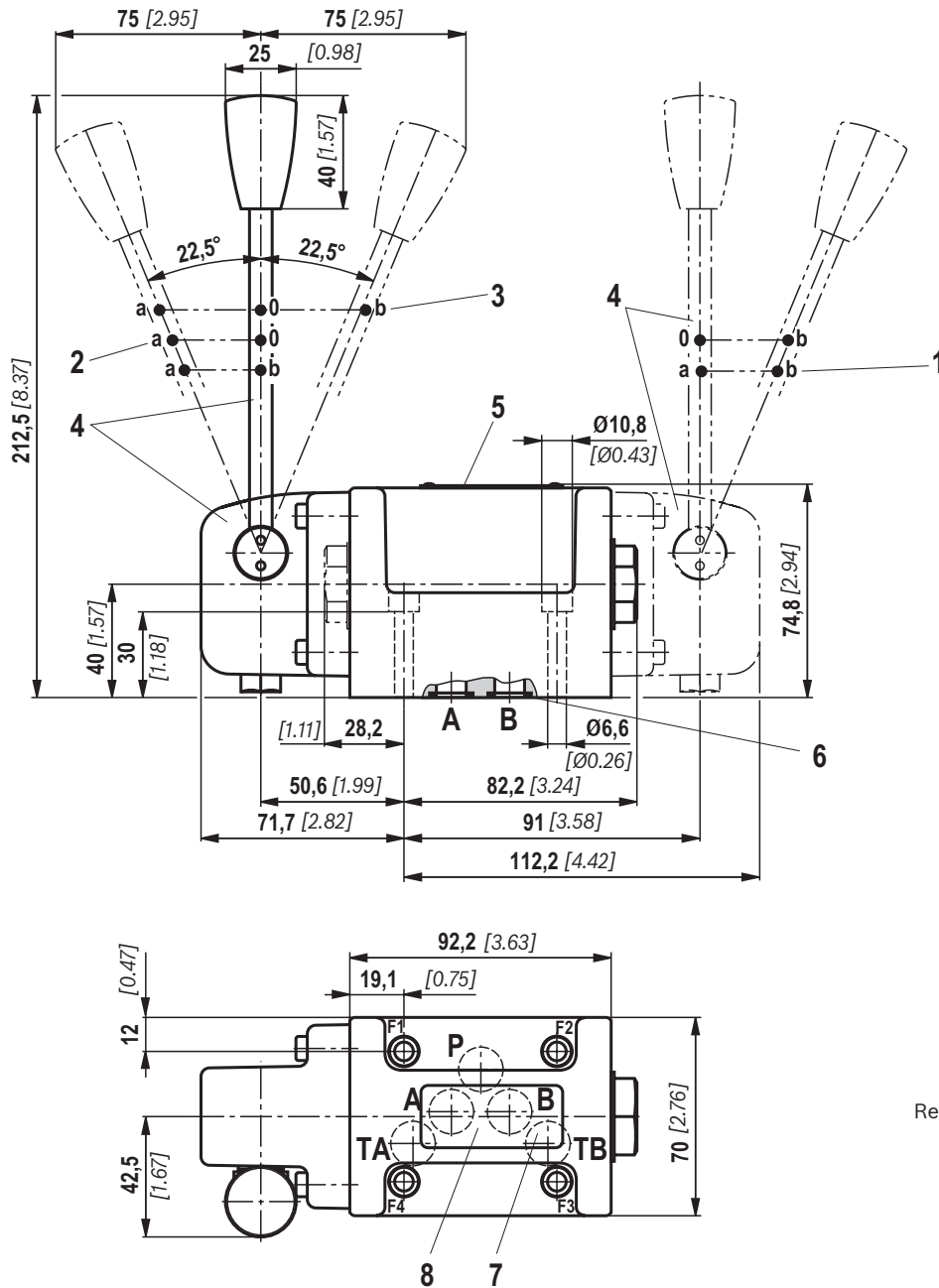

- 1 Valves with 2 switching positions, symbol B and .B
- 2 Valves with 2 switching positions, symbol A, C, D .A
- 3 Valves with 3 switching positions
- 4 Cover and hand lever
- 5 Name plate
- 6 Identical seal rings for port A, B, P, TA, TB
- 7 Additional port TB can optionally be used
- 8 Porting pattern according to ISO 4401-05-04-0-05 and NFPA T3.5.1 R2-2002 D05

Notes

- ▶ Deviating from ISO 4401, port T is called TA in this data sheet; port T1 is called TB.
- ▶ For valves with 2 switching positions and symbols B and .B, the hand lever is installed on valve side B.
- ▶ The dimensions are nominal dimensions which are subject to tolerances.

Valve mounting screws and subplates see page 14.

Dimensions: Type WM
(dimensions in mm [inch])

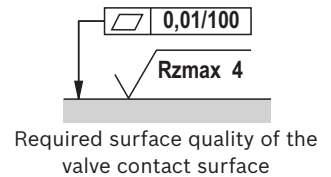
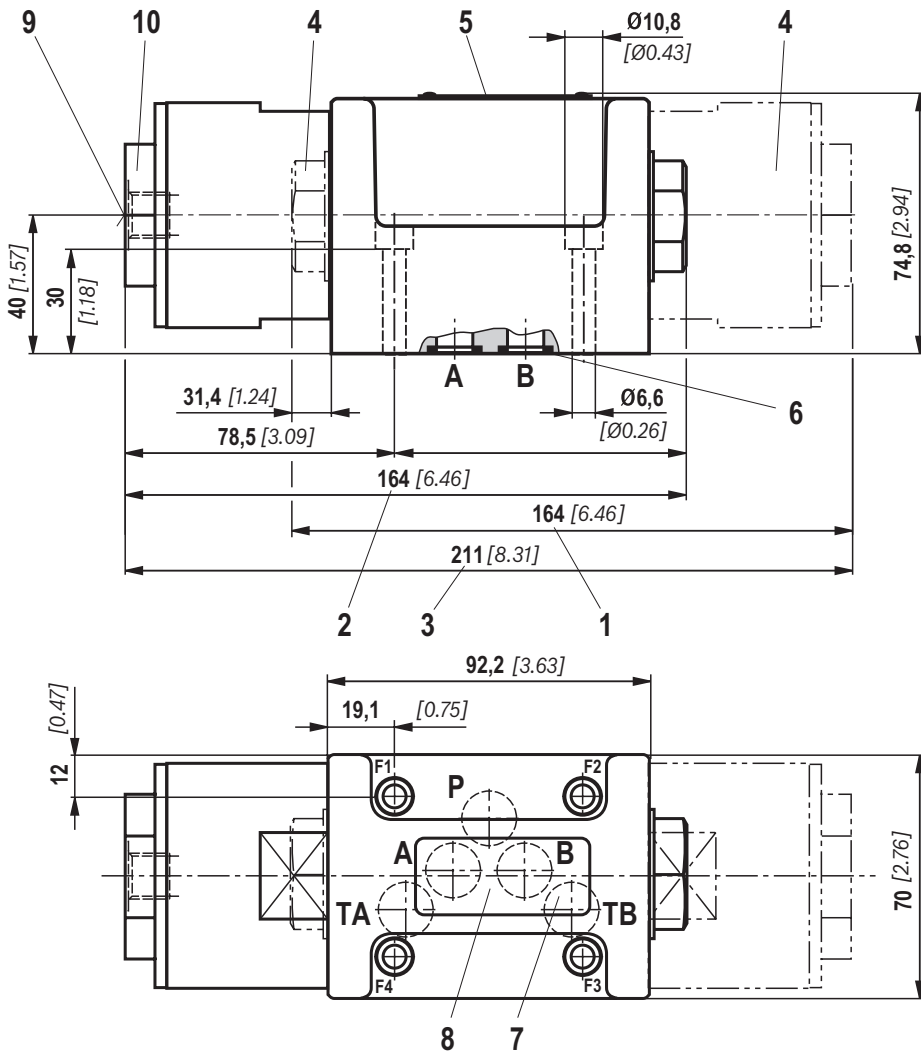

- 1 Valves with 2 switching positions, symbol B and .B
- 2 Valves with 2 switching positions, symbol A, C, D .A
- 3 Valves with 3 switching positions
- 4 Cover and plug screw
- 5 Name plate
- 6 Identical seal rings for port A, B, P, TA, TB
- 7 Additional port TB can optionally be used
- 8 Porting pattern according to ISO 4401-05-04-0-05 and NFPA T3.5.1 R2-2002 D05
- 9 Pilot oil port G1/4 (version "-")
Pilot oil port 7/16" - 20 UNF (version "/12")
- 10 Socket

- Notes**
- ▶ Deviating from ISO 4401, port T is called TA in this data sheet; port T1 is called TB.
 - ▶ The dimensions are nominal dimensions which are subject to tolerances.
 - ▶ When screwing in/releasing the connection tube on the pilot oil port (9), the bushing (10) must be secured against twisting by using an open-end wrench.

Valve mounting screws and subplates see page 14.

Dimensions: Type WP
(dimensions in mm [inch])

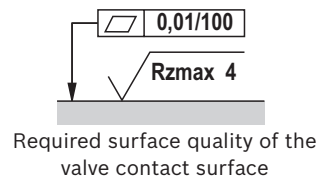
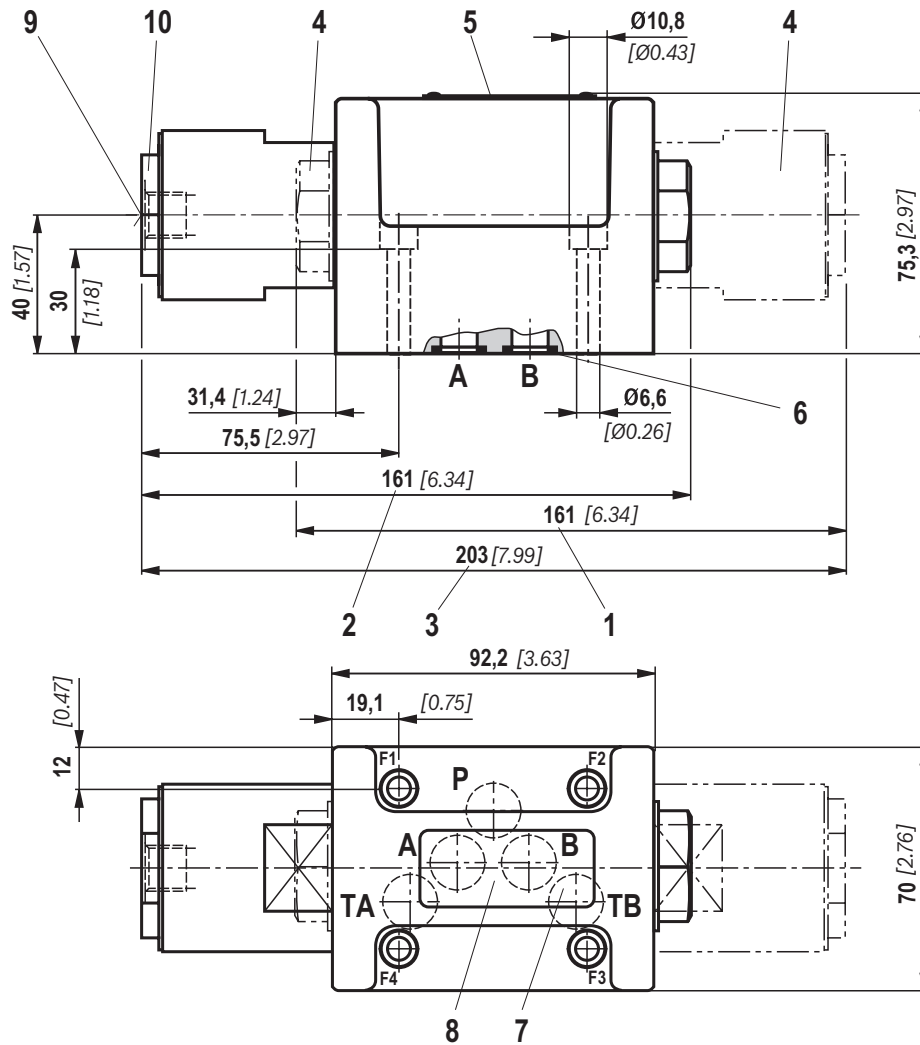

- 1 Valves with 2 switching positions, symbol B and .B
- 2 Valves with 2 switching positions, symbol A, C, D, EA...
- 3 Valves with 3 switching positions
- 4 Cover and plug screw for valves with 2 switching positions, symbol B, Y, EB...
- 5 Name plate
- 6 Identical seal rings for port A, B, P, TA, TB
- 7 Additional port TB can optionally be used
- 8 Porting pattern according to ISO 4401-05-04-0-05 and NFPA T3.5.1 R2-2002 D05
- 9 Metric pilot oil port: G1/4
UNC pilot oil port: 7/16" - 20 UNF
- 10 Socket

Notes

- ▶ Deviating from ISO 4401, port T is called TA in this data sheet; port T1 is called TB.
- ▶ The dimensions are nominal dimensions which are subject to tolerances.
- ▶ When screwing in/releasing the connection tube on the pilot oil port (9), the bushing (10) must be secured against twisting by using an open-end wrench.

Valve mounting screws and subplates see page 14.